

This adapter threads into your lathe's face plate so that you can add decorative carving details to a turned part, then return it to your lathe for further turning, without removing the face plate. The 5/8"-dia. post makes it easy to mount the adapter into the Veritas® Carver's Vise (or any other vise that takes a 5/8" shaft). The adapter is available in four thread sizes (1" × 8 tpi, 3/4" × 16 tpi, 1 1/4" × 8 tpi, and 33mm × 3.5mm).

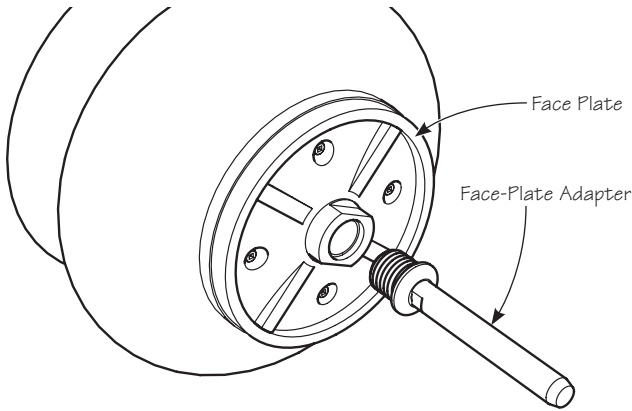

Figure 1: Face-plate adapter.

Installing the Adapter

1. Thread the adapter into your lathe's face plate and lock it in place with a 1/2" wrench.

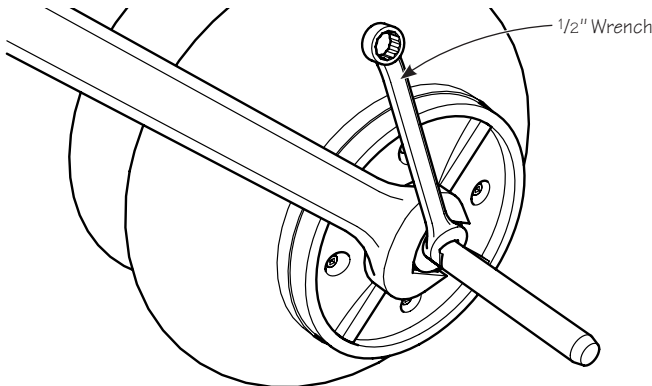

Figure 2: Threading the adapter into a face plate.

2. Loosen the clamp handle on the carver's vise and insert the adapter's post in the hole in the clamp shaft.

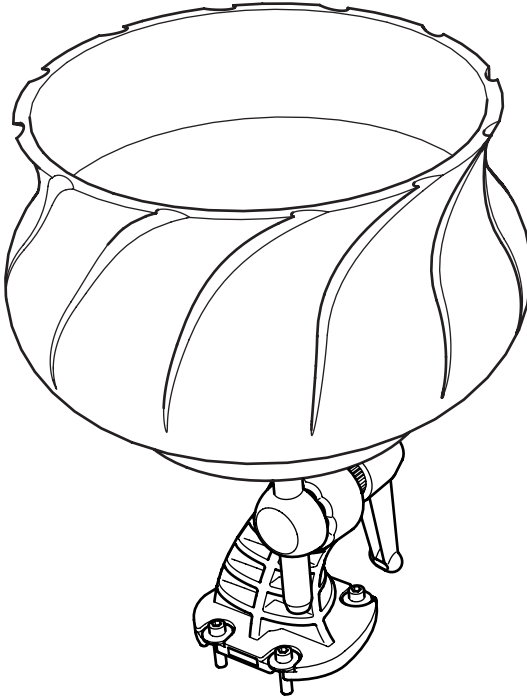

Figure 3: Inserting the adapter into the carver's vise.

veritas[®] Tools Inc.

814 Proctor Avenue 1090 Morrison Drive
Ogdensburg, New York Ottawa, Ontario
13669-2205 USA K2H 1C2 Canada

customerservice@veritastools.com
www.veritastools.com