

Patent Pending.

The skew registration jig is used with the Veritas® Mk.II Honing Guide, allowing skew chisels and blades to be accurately and repeatedly sharpened and honed to a very sharp edge. The jig attaches to the guide using the same dovetail feature along the front of the blade carrier as the standard registration jig. It is used with the blade carrier set to the ② (yellow) standard-angle configuration.

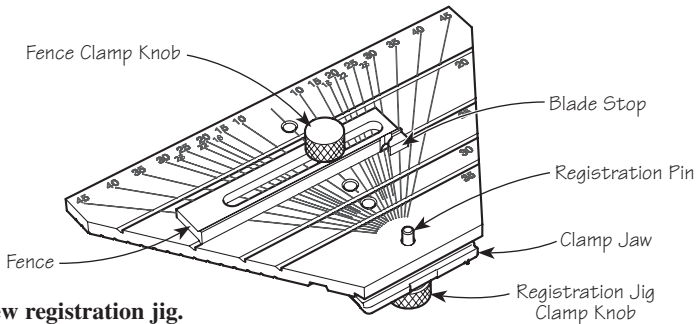

Figure 1: Skew registration jig.

The jig is designed to hone bevel angles of 20°, 25°, 30° and 35°, and skew angles from 10° to 45° in 5° increments (see Figure 2). Skew angles for 18°, 22° and 28° are also included, as these are common angles for skew plane blades.

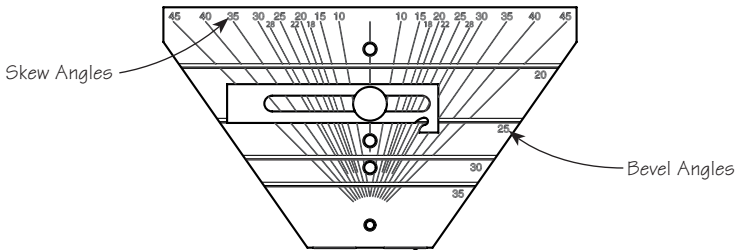

Figure 2: Skew registration jig markings.

Step 1: Setting the Bevel Angle

Place the fence in the appropriate groove for the bevel angle you are honing. The fence shown in Figure 2 is set for a 25° bevel angle. Note that the bevel angle is measured normal to the cutting edge, not parallel to the length of the blade. (See Figure 3.)

The fence is reversible to accommodate left and right skews. Simply flip it over end for end to orient the blade stop left or right, as needed.

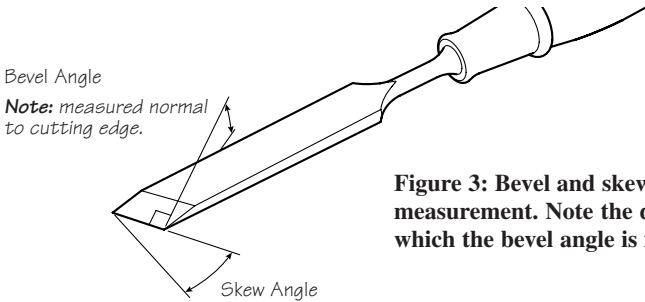

Figure 3: Bevel and skew angle measurement. Note the direction in which the bevel angle is measured.

Step 2: Setting the Skew Angle

a) Establishing the Skew Angle using the Jig

If the skew angle is known, slide the fence so that the blade stop is tangent to the appropriate skew angle line (see **Figure 4**).

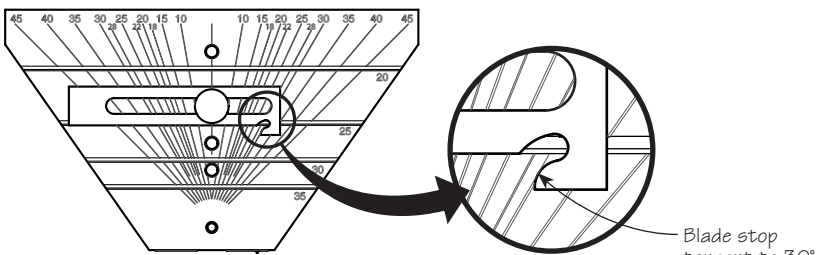

Figure 4: Setting the blade stop to a known skew angle.

You can also use the jig to determine the skew angle, as shown in **Figure 5**. Slide the blade along the fence until the edge of the blade aligns with one of the graduations. Once you have determined this to be the skew angle, slide the fence into place, as noted above.

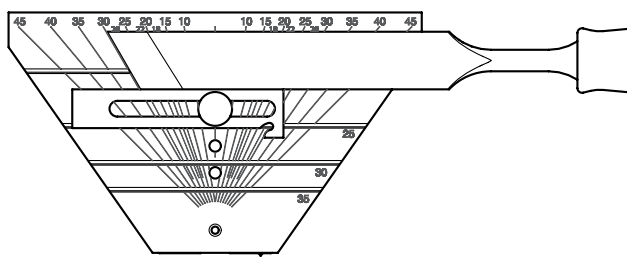

Figure 5: Determine the skew angle.

b) Establishing the Skew Angle using the Blade

If you wish to hone a non-standard skew angle, or if you simply wish to maintain the existing angle, you can use the cutting edge of the blade as a guide. Place the long side of the blade against the registration pin and pivot the blade about the pin so that the cutting edge is parallel to and in full contact with the fence, as shown in **Figure 6**. Slide the fence so that the blade stop contacts the side of the blade and tighten the fence clamp knob (finger tight is sufficient).

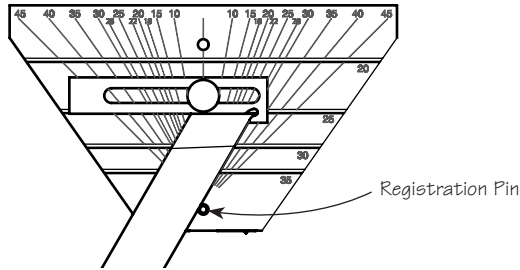

Figure 6: Configuring the jig to reproduce an existing skew angle.

Step 3: Installing the Blade

Once the registration jig has been configured, slide it onto the dovetail feature along the front of the blade carrier, and tighten the registration jig clamp knob. In general, position the jig so the center of blade bevel is as centered as possible under the roller. This will provide a more stable assembly when honing, and assist in keeping the guide centered on the stone.

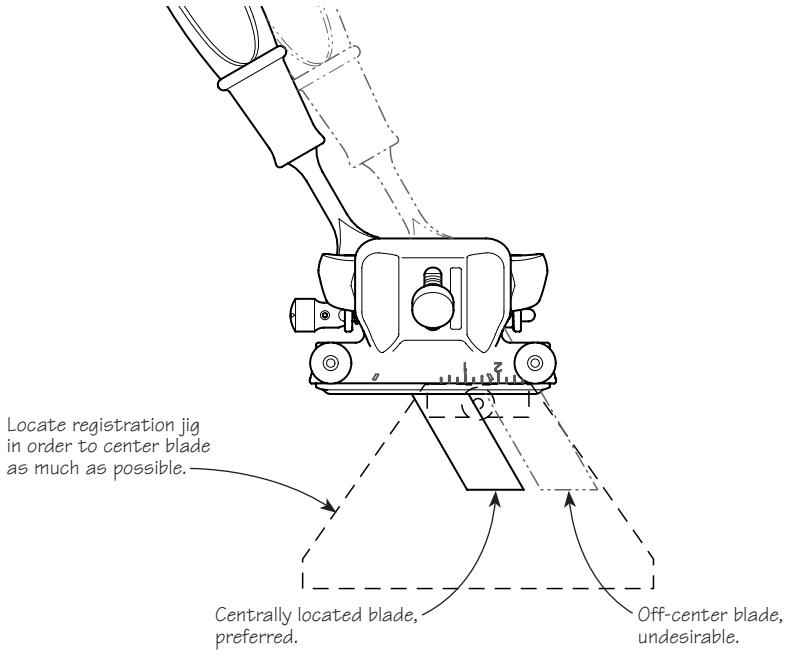

Figure 7: Blade centered in the honing guide.

Note: The scale on the top of the blade carrier is irrelevant when using the skew registration jig.

Loosen the two blade clamp knobs on the blade carrier. Open the clamp bar wide enough to slide the blade in. The knobs must be loosened and tightened in small increments. Do not tighten or loosen one side substantially more than the other; otherwise, the clamp bar or knobs may jam.

Hold the honing guide upside down, and slide the blade in the honing guide such that the long side of the blade bears against the registration pin and the blade stop, and its cutting edge bears against the fence. Tighten the knobs firmly, but avoid overtightening.

Loosen the skew registration jig clamp knob, slide the registration jig off of the blade carrier, and sharpen the blade.

***Note:** The skewed blade orientation results in a rotational force on the blade not encountered when sharpening a straight blade. As such, it may not be possible to put as much pressure on the blade as it would with a straight blade.*

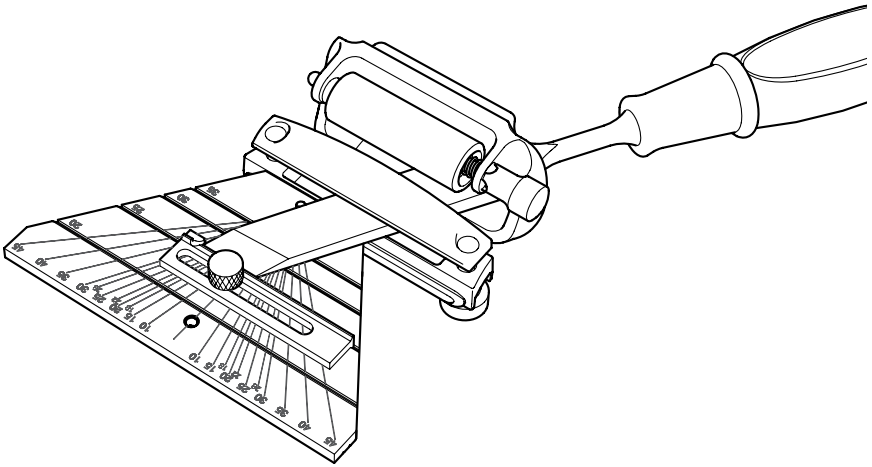

Figure 8: Installing the registration jig and blade.

Veritas® Tools Inc.

814 Proctor Avenue
Ogdensburg, New York
13669-2205 USA

1090 Morrison Drive
Ottawa, Ontario
K2H 1C2 Canada