

veritas[®]
Small Shoulder Plane



U.S. Pat. No. 7,117,602
U.S. Des. Pat. D602,327

The Veritas® Small Shoulder Plane is designed for one-handed use. It is proportioned to handle multiple tasks, from trimming shoulders for a perfect fit to cleaning the bottom of dadoses. At 6¼" long by ½" wide and weighing just over 1 lb, it is a cross between a medium shoulder plane and a bullnose plane. The ductile cast iron body is accurately machined and ground so that the sole and sides are flat and square, allowing the plane to be used on its side for accurately shooting the shoulder of a tenon.

The rounded lever cap and crowned back fit comfortably in the hand for shooting or plowing. The through-hole in the body adds to grip security but has to be experienced to be understood. The plane's adjustable toe lets you narrow the mouth for very fine shavings with minimum tear-out. The low bed angle of 15° combined with the 25° blade bevel results in a cutting angle of 40° for exceptional end-grain cutting performance. Set screws along the side enable you to accurately position the blade and do not require adjustment when replacing the blade after sharpening. The lapped blade is ⅛" (0.125") thick and is available in A2 or O1 tool steel.

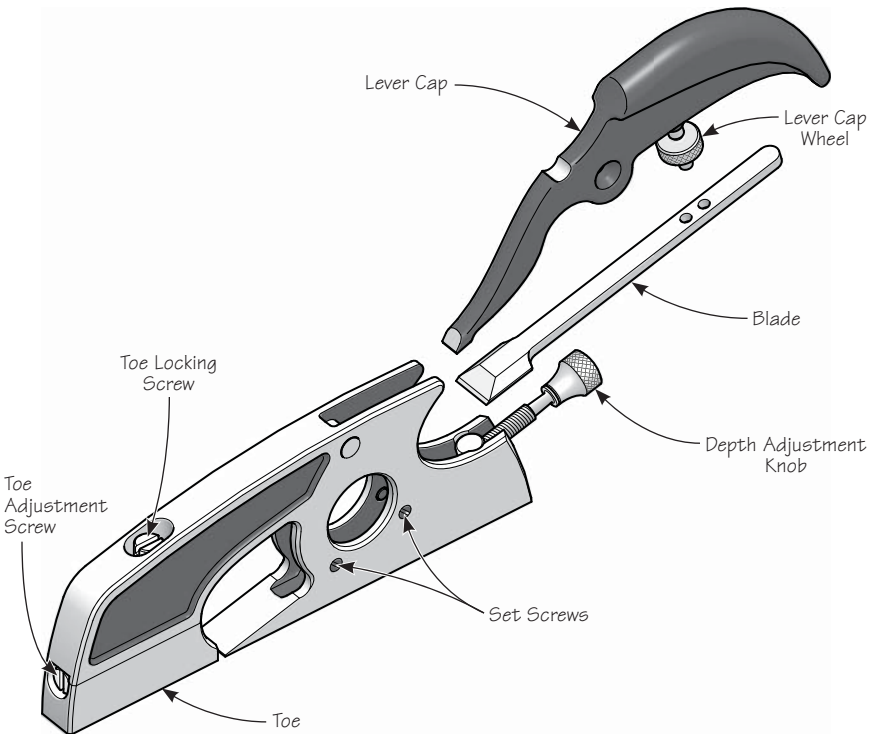

Figure 1: Shoulder plane components.

Positioning the Blade

The ideal blade position will be achieved when the cutting edge is parallel to the sole and the adjacent edge projects slightly from the body on the working side. This is most easily done with the four blade adjustment set screws (two on each side of the plane). Back off the lever cap wheel to free up the blade, and adjust the pair of set screws on the working side of the plane approximately flush with the body. With your finger, shift the blade over in that direction to seat the blade against the set screws. Since the blade will sit proud of the body on the working side, but much farther than required, adjust the two contacting set screws (on the working side) until the desired blade position is attained (just proud of the side surface of the plane body). To finish, tighten the out-of-contact set screws until they touch the blade, then back them off $\frac{1}{8}$ turn or less. (If the blade is in firm contact with all four set screws, depth of cut adjustment will be difficult or impossible.)

Note: As supplied, the blade is slightly wider than the body of the plane. You can position the blade relative to the working side as outlined above, or grind the sides of the blade down so that it aligns with the sides of the plane body.

Setting the Blade



Caution: Be aware that the blade is sharp; careless handling can result in serious injury.

To initially set the blade, open the mouth fully and place the plane on a flat wood surface (e.g., a scrap of stock). Lightly clamp the blade (bevel up) with the lever cap wheel and advance the blade until it just touches the wood.

Depth Adjustment

Flip the plane to a sole-up position, then sight along the sole to ensure the blade edge is parallel to the sole and advance or retract it as required. To a small degree, the depth of cut is also influenced by the amount of clamping force applied to the lever cap wheel. As you tighten the wheel, you increase the blade clamping force that, in turn, results in a slight deflection of the blade bed. This is normal and does not affect performance. A very light clamp force will deflect the blade bed 0.0005". A hard clamp force will deflect the blade bed by as much as 0.003". Extremely small adjustments to blade depth can be achieved by changing the blade clamping force. Clamp the blade ($\frac{1}{8}$ turn should be ample — **do not overclamp**) and take a test cut on a **flat** scrap of wood. If the shaving is not of uniform thickness across its width, you will have to reshape your blade so that its cutting

edge is parallel to the sole of the plane (which should also be exactly 90° to the blade side). To do this, first scribe a line behind the blade's edge, along the bed lip for reference, grind to this line, then hone for sharpness.

Before advancing the blade at any time, check the mouth opening to be sure you don't run the blade against the adjustable toe. It is a simple matter to close the mouth to the desired opening after you have reached the right blade projection. Better to dull the blade in use than when adjusting it.

Backlash and How To Avoid It

Even the best of planes, including this one, have slight backlash in the blade advance mechanism (play between threads and other moving parts). To eliminate the possibility of the blade shifting backward unpredictably as the backlash is taken up, the final setting should always be made with the blade being advanced by the clockwise movement of the thumbscrew. If you need to retract the blade slightly, retract it more than required, and finish by **advancing** it to its desired position. This takes up all the play in the forward direction, resisting the backward forces experienced by the blade.

Mouth Adjustment

The movable toe piece enables you to easily and accurately set the mouth, the gap between the blade and the toe piece. Generally, you will want a mouth as small as will allow the shaving to escape. The reason for this is that a tight mouth supports the wood ahead of the blade, preventing tear-out, a shaving propagating below the surface of the workpiece.

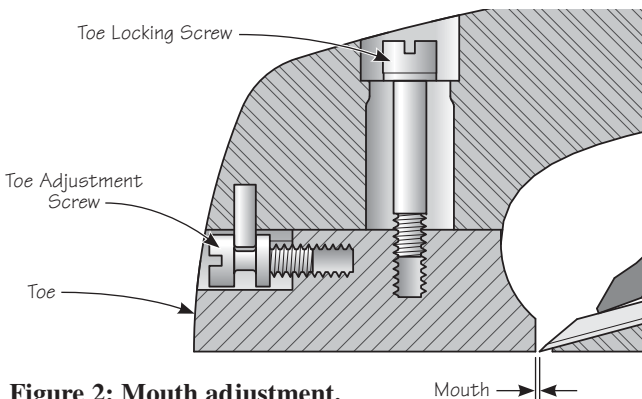

Figure 2: Mouth adjustment.

Loosen the toe locking screw with a slot screwdriver and adjust the position of the toe by turning the toe adjustment screw to move the toe forward or backward as required. Tighten the toe locking screw firmly, but avoid overtightening.

Blade Sharpening

The small shoulder plane has a bed angle of 15° and the blade comes finely ground at an angle of 25° . Since the blade is used bevel up, the effective cutting angle will be 40° .

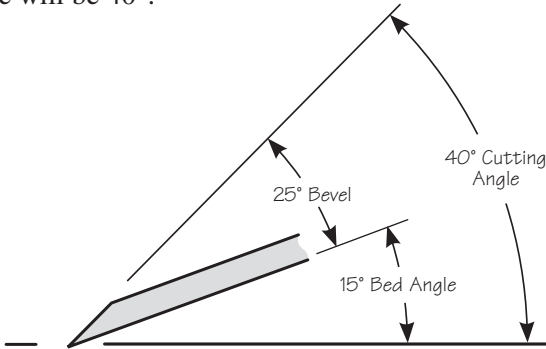

Figure 3: Blade geometry as supplied.

Additional honing will improve performance. The finely ground blade face can be readily lapped to a mirror finish. A secondary or micro-bevel can easily be added and makes for fast re-honing, without having to hone the entire primary bevel.

One final note of caution, because the blade in a shoulder plane is aligned with the side of the plane in addition to being parallel to the sole, the cutting edge must be kept perfectly square with the sides of the blade when sharpening it.

Care and Maintenance

The body of this shoulder plane is ductile cast iron and comes treated with a rust preventative. Remove this using a rag dampened with mineral spirits. Clean all machined surfaces, including the area under the nose and the toe itself.

We recommend that you initially, then periodically, apply a light coat of silicone-free paste wax or Waxilit® sliding agent and glue release to seal out moisture and prevent rusting (as well as act as a lubricant for smoother planing). Wipe off any wood dust from the surfaces that you will be waxing, apply a light wax coating, let dry, then buff with a clean soft cloth. At the same time, the solvents in the wax will remove any harmful oils left from your fingers that can lead to corrosion. This is especially important with planes that are gripped on the machined surfaces, such as shoulder planes.

Keep in mind that typical paste wax contains silicone that, if transferred to your workpiece, could cause finishing problems such as "fish eyes". Before treating a plane with a sealant, wipe off any fingerprints with a cloth dampened with a small amount of light machine oil. Remove any residual oil; then apply the sealant to the plane's sole and cheeks.

If storage conditions are damp or humid, the plane should, in addition to the treatment outlined above, be wrapped in a cloth or stored in a plane sack. This precaution will also guard against dings and scratches.

Every so often, take the plane apart to clean and lubricate it where necessary. Remove the lever cap, blade, adjustment mechanism and toe from the body. Clean all parts with a cloth dampened with a dab of light machine oil. The blade bed and machined contact surfaces between the body and toe, as well as the adjustment components (pivot, threaded shaft and traveller), will benefit from a light coat of oil to keep them working freely. For corroded plane bodies, we recommend you first remove the rust with a fine rust eraser, then treat as described above.

The bright finish on the brass components can be maintained as above. If a patina finish is preferred, simply leave the brass components unprotected until the desired level of oxidation has occurred, then apply a sealant. If you want to make them bright and shiny again, you can revitalize the surface with a brass polish.

Accessories

05P47.02 Replacement A2 Blade
05P47.52 Replacement O1 Blade

veritas[®] Tools Inc.

814 Proctor Avenue 1090 Morrison Drive
Ogdensburg, New York Ottawa, Ontario
13669-2205 USA K2H 1C2 Canada

798
© Veritas Tools Inc. 2011

customerservice@veritastools.com
www.veritastools.com

INS-386 Rev. B
Printed in Canada.