

Shooting Board

The Veritas® Shooting Board comes fully assembled; however, it is necessary to adjust the parts to fit your shooting plane and to set the fence for accurate cuts. As you use the shooting board, it may be necessary to periodically repeat these steps to maintain accurate results.

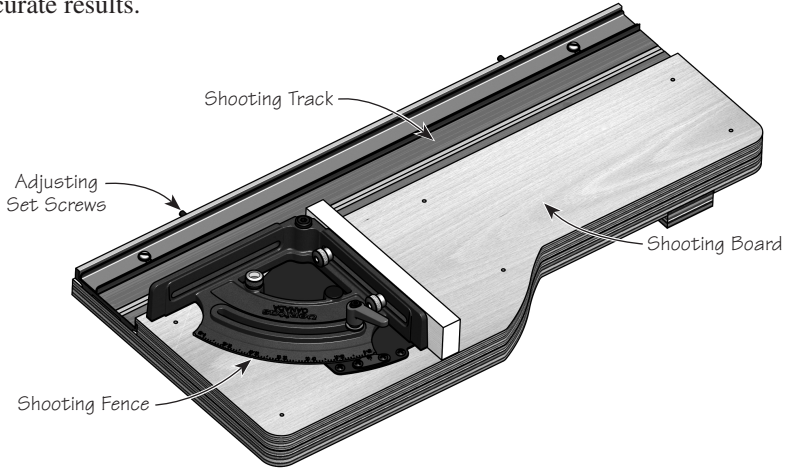

Figure 1: Shooting board components.

Adjusting the Track

The first step is to set the track to fit your shooting plane. Loosen the pan-head screws that hold the rail in place. Back the adjusting set screws off so that your plane can fit in the track. To set a small amount of clearance, place a piece of paper between the rail and the plane and adjust the set screws until the shooting plane is suitably captured in the track base, but can still move freely along it. Tighten the pan-head screws and remove the paper.

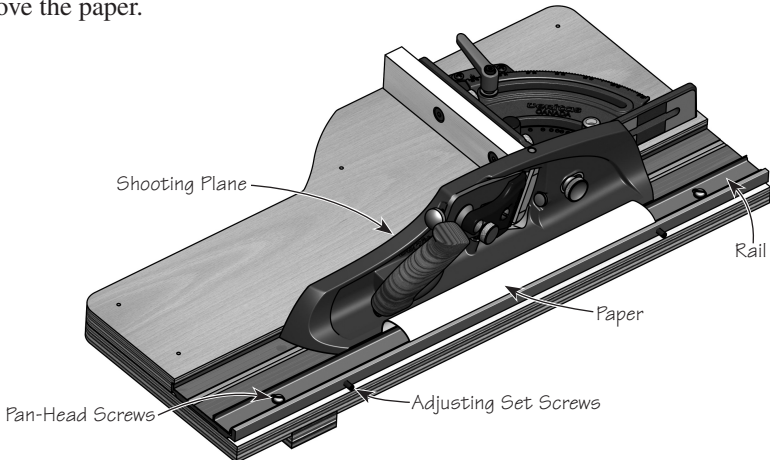

Figure 2: Adjusting the track.

Adjusting the Fence

Loosen the gyratory handle and the four #8 screws that hold the detent plate and zero scale in place. Ensure the spring plunger is engaged in the detent plate so that the fence and plate move together. Place an accurate square between the plane's sole and the fence.

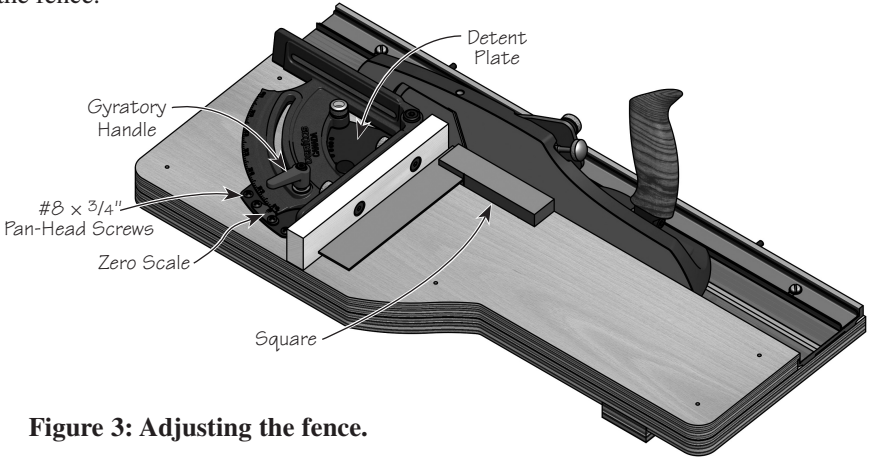

Figure 3: Adjusting the fence.

Verify that there is no angular play between the fence and the detent plate when the spring plunger is bottomed out in the fence. If there is, use a screwdriver to adjust the spring plunger, as shown in **Figure 3a**.

Tighten the outer two #8 screws (the ones that only go through the detent plate) and the gyratory handle. Align the middle graduation on the zero scale with the 0° graduation on the fence and secure it in place with the two remaining pan-head screws.

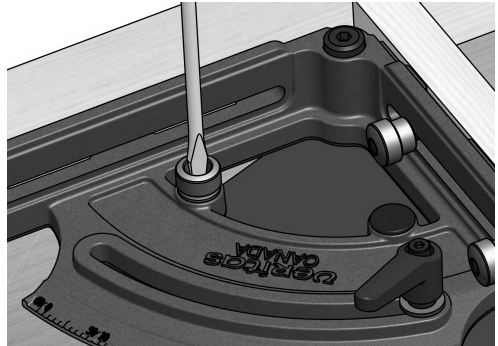

Figure 3a: Adjusting the spring plunger.

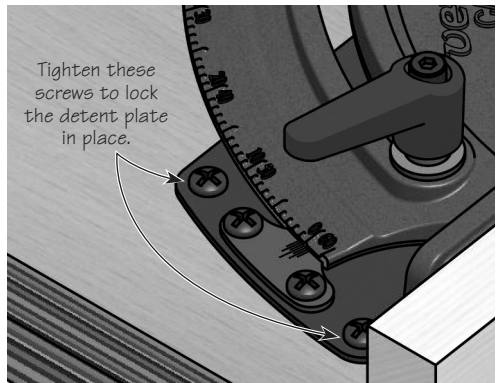

Figure 4: Locking the detent plate in place.

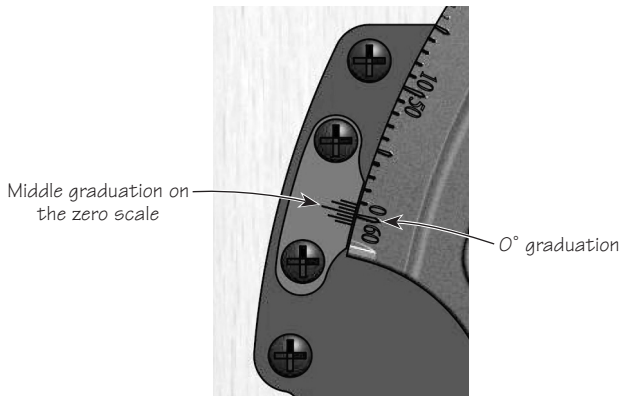

Figure 5: Locating and locking the zero scale.

The shooting board fence can be set accurately to within 0.25°.

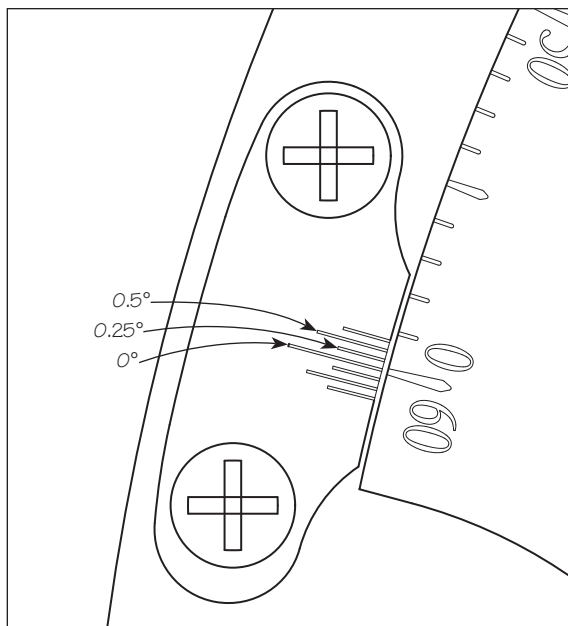

Figure 6: Setting the fence angle.

The detents are pre-set for miters to make multi-sided parts. Select the pre-set miter angle detent that relates to the number of sides on the structure you are making:

Angle	Number of Sides
0°	Square Corners
18°	10
22.5°	8
25.7°	7
30°	6
36°	5
45°	4
60°	3

Final Adjustments

Set the wood sub-fence so that it contacts the sole of the plane. This part is sacrificial; it should always be set so that it fully supports the workpiece in order to minimize tear-out.

Care and Maintenance

The adjustments detailed above will need to be repeated periodically in order to maintain accurate results.

As noted above, the sub-fence is sacrificial and will eventually need to be replaced. It can be made from quality 1 × 2 material, preferably a softwood such as pine. The 9/16" diameter countersinks should be such that the heads of the mounting screws are flush or recessed from the face of the sub-fence.

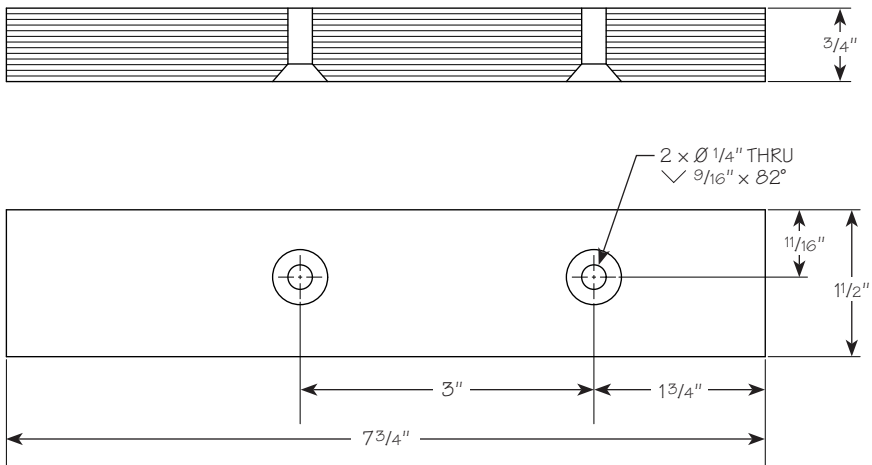

Figure 7: Dimensions for a sub-fence.